

各部の名前

■以降の設置説明は S2136L モデルを例として説明しています。

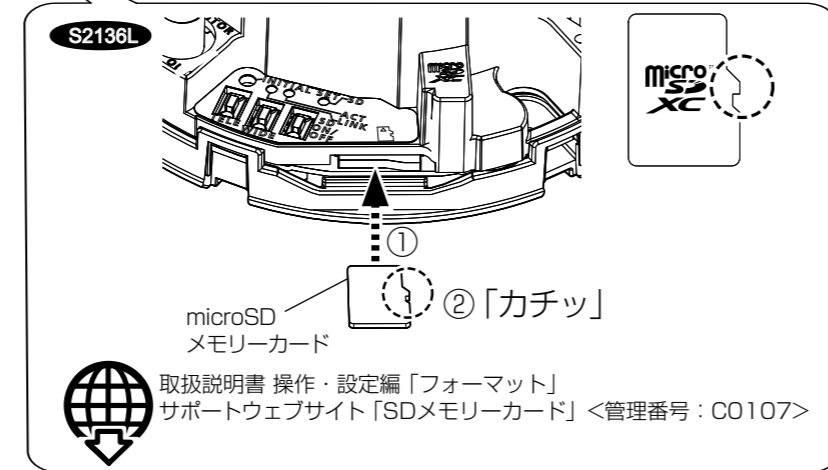

Step3

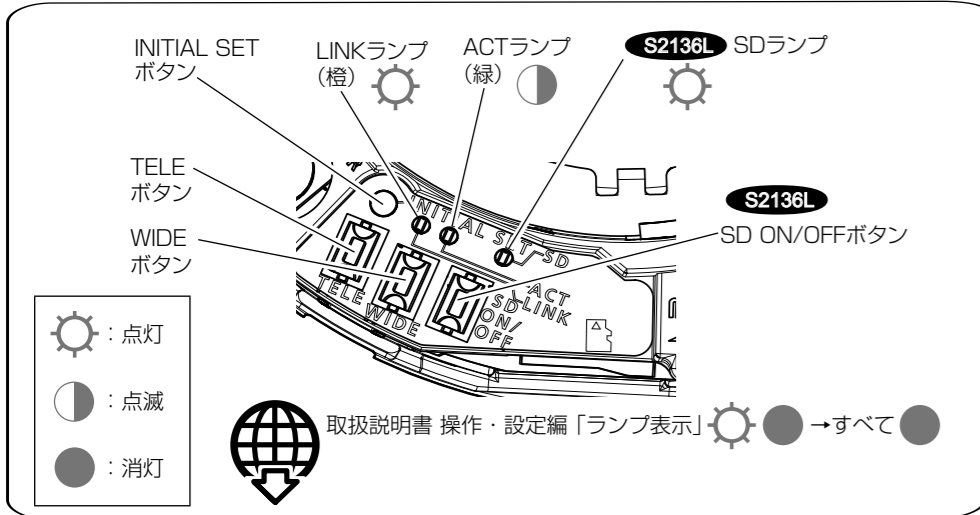
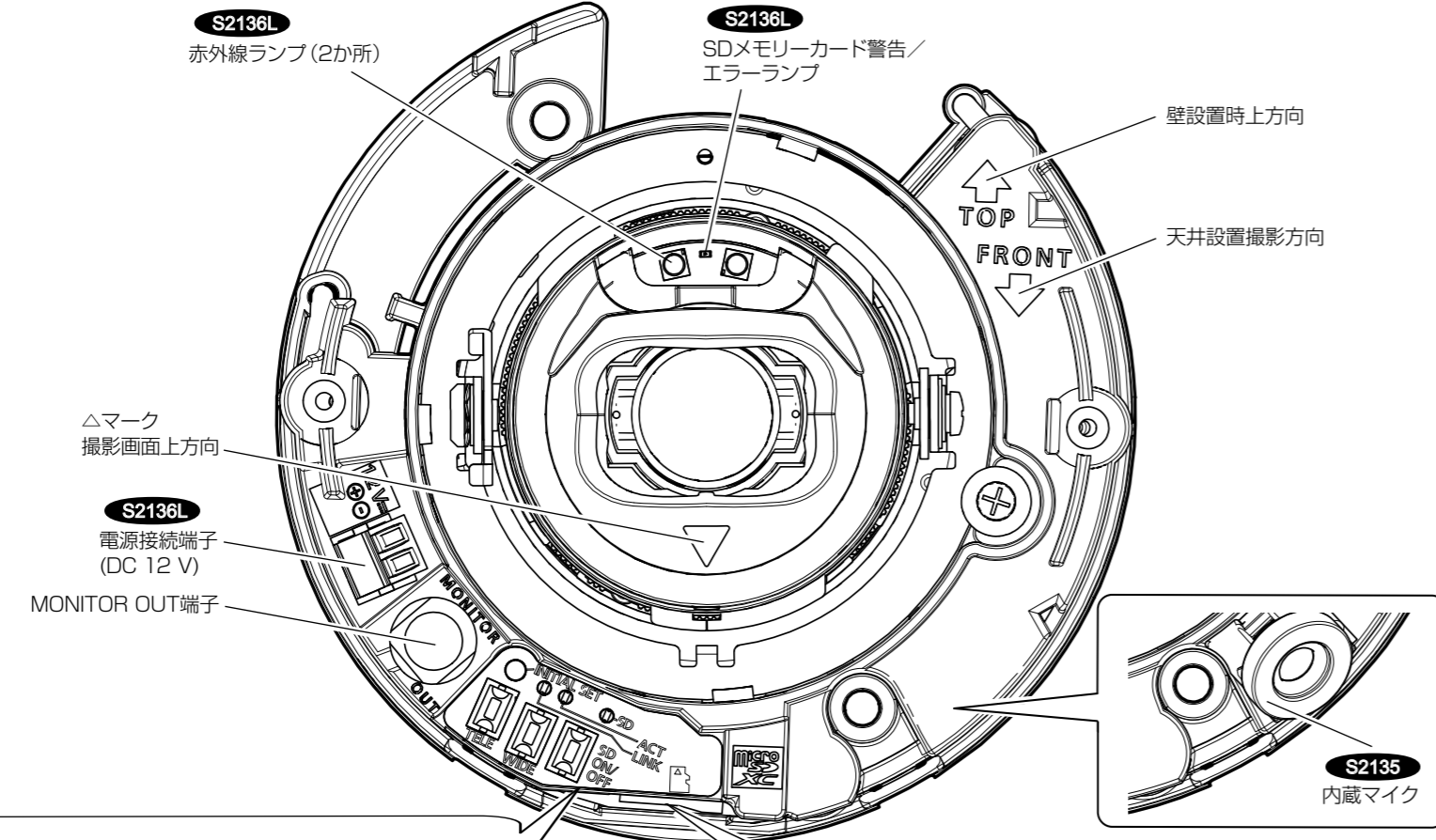
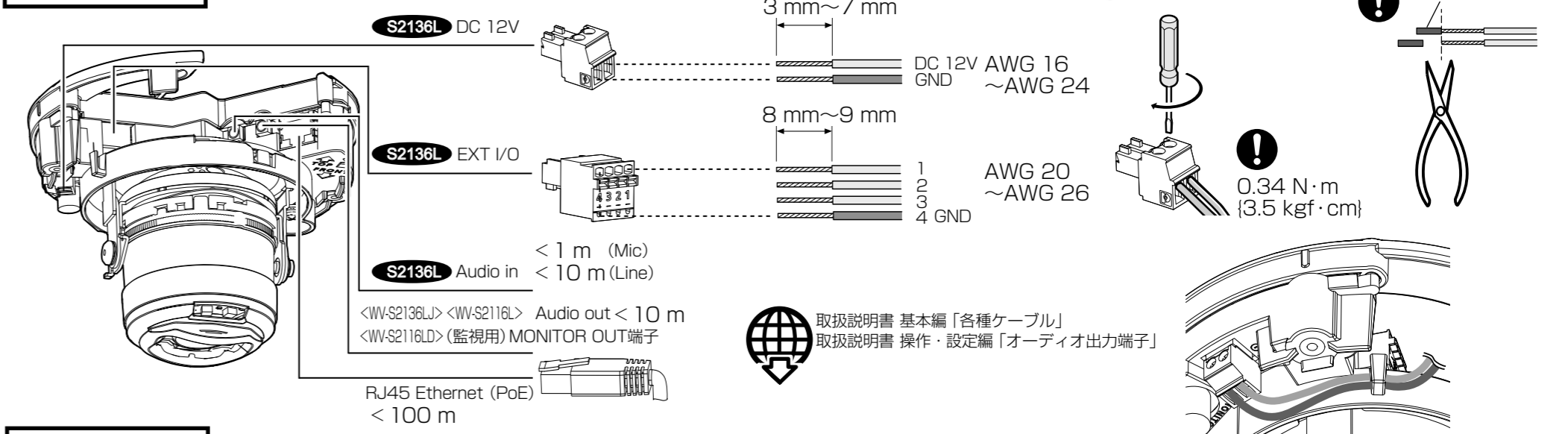

Step4

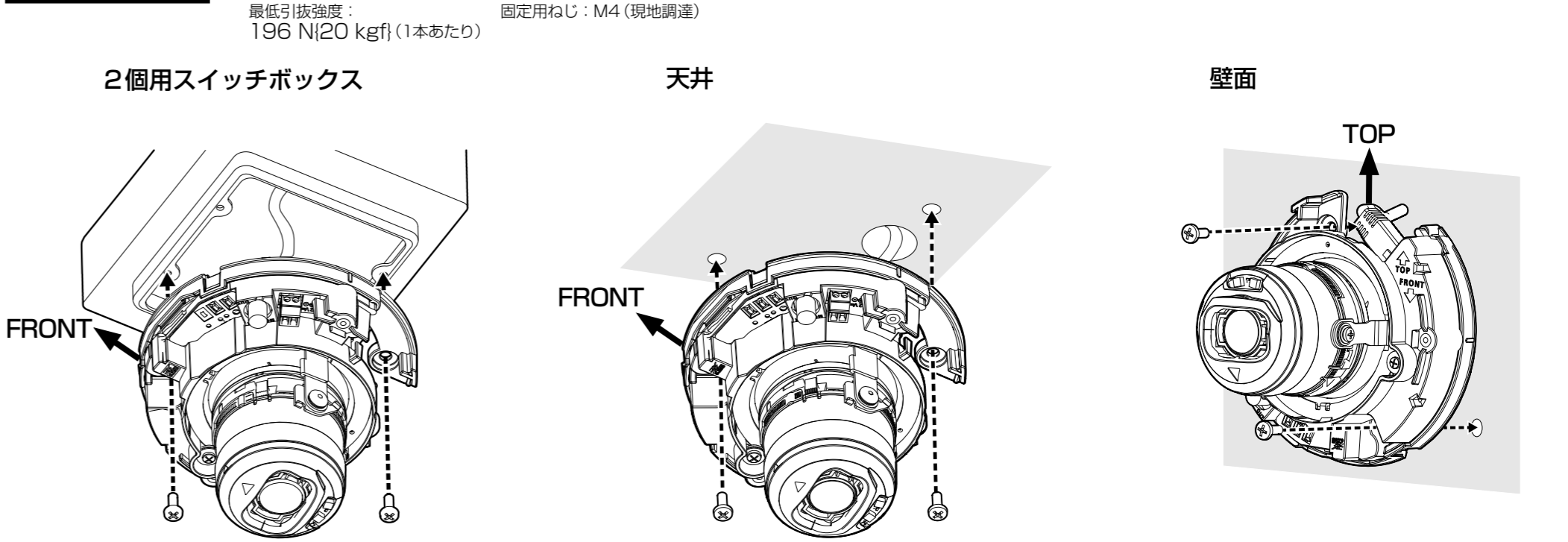

Step1 前準備

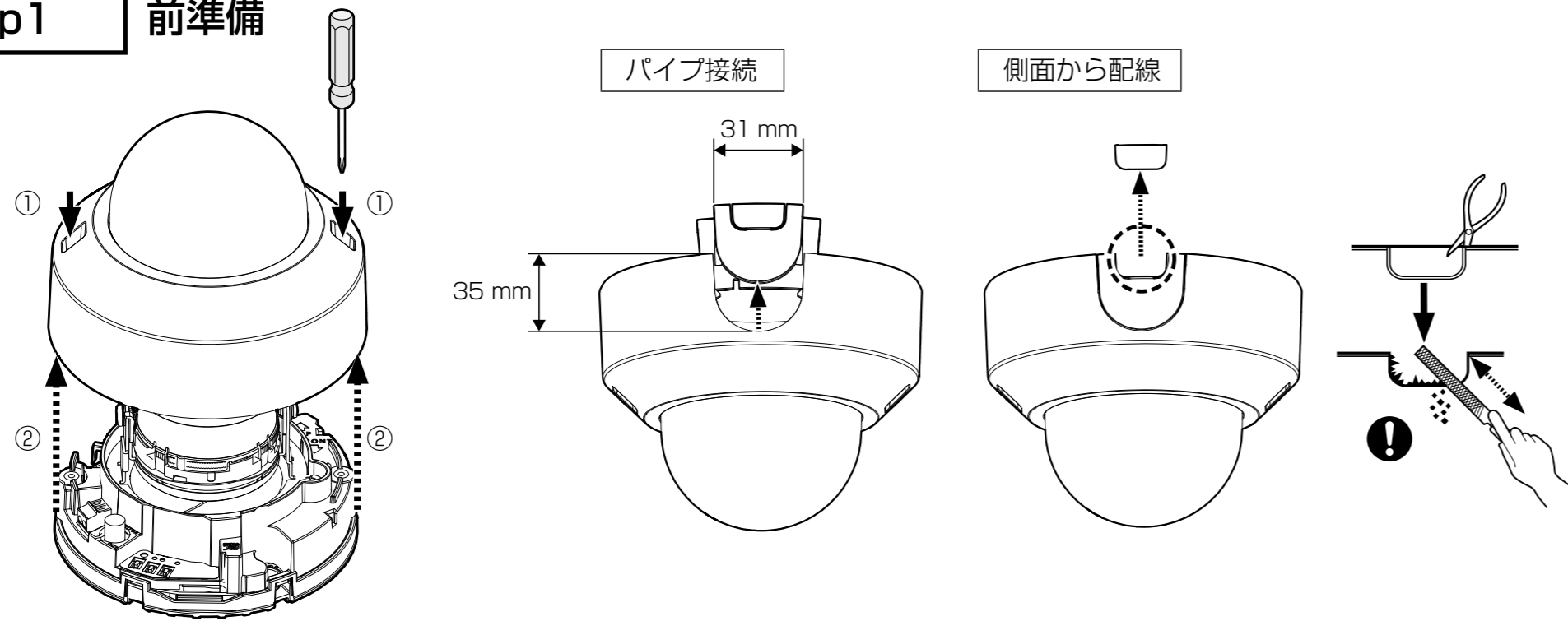

Step2

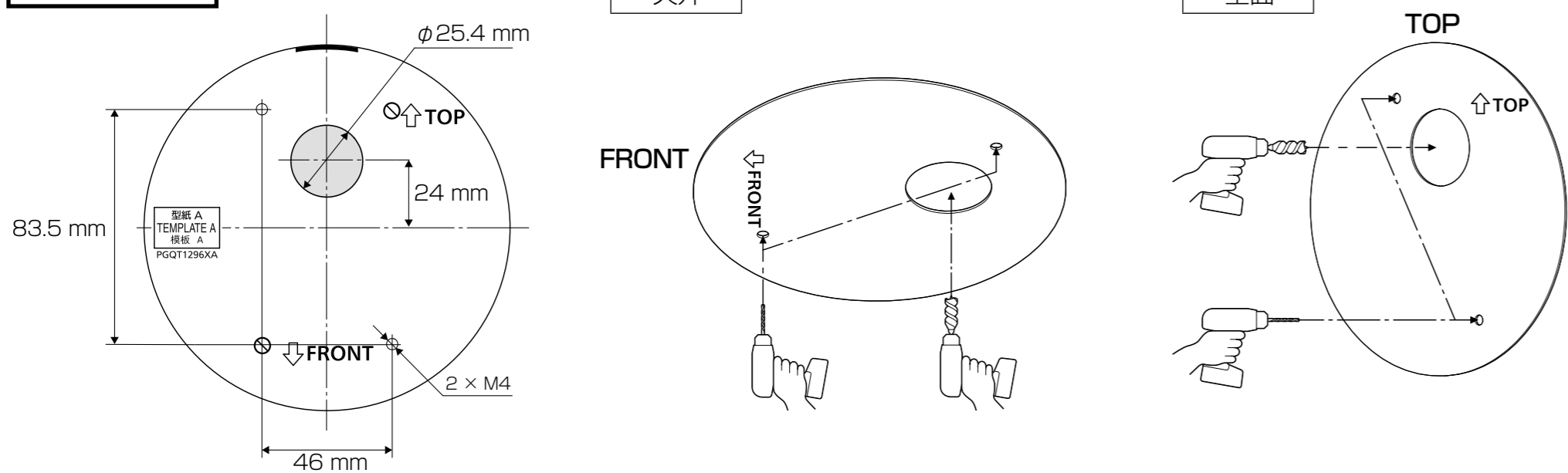

Step5

